

Relief valves VSBV 25

TECHNICAL INFORMATION

- For gaseous media
- Inlet pressure range up to 4 bar
- Adjustable opening pressure 20–500 mbar
- Suitable for hydrogen



Contents

Contents	2
1 Application	3
1.1 Application examples	3
2 Certification	4
2.1 Certificate download	4
2.2 Declaration of conformity	4
2.3 UKCA certified	4
2.4 Eurasian Customs Union	4
2.5 REACH Regulation	4
2.6 China RoHS	4
3 Function	5
4 Selection	6
4.1 ProFi	6
4.2 Type code	6
5 Project planning information	7
5.1 Installation	7
5.2 Pressure levels	8
5.3 Hydrogen	8
6 Accessories	9
6.1 Exhaust ABG	9
6.1.1 Installation	9
6.1.2 Selection	9
6.1.3 Type code	10
6.1.4 Technical data	10
7 Technical data	11
7.1 Ambient conditions	11
7.2 Mechanical data	11
7.3 Dimensions	11
8 Spring table	12
9 Maintenance cycles	13
For more information	14

1 Application



Relief valve for relieving brief pressure surges in control systems thus preventing the safety shut-off valve JSAV from being activated unintentionally. The VSBV reduces too high a pressure increase due to gas creeps which are the result of gas pressure regulators that are not tight closing.

Compulsory for all gas pressure control systems in conjunction with a safety shut-off valve JSAV pursuant to EN 746-2.

1.1 Application examples

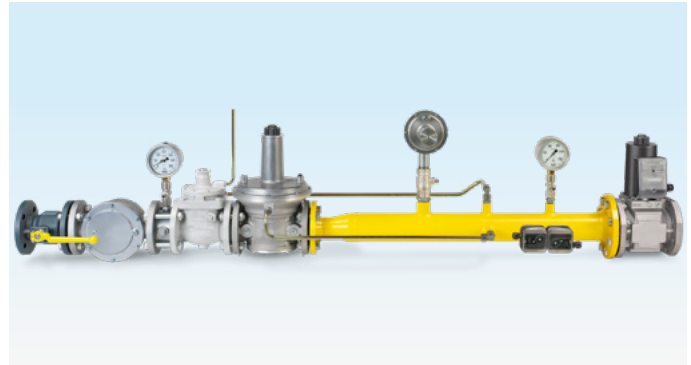

Gas inlet section

2 Certification

2.1 Certificate download

Certificates – see www.docuthek.com

2.2 Declaration of conformity



We, the manufacturer, hereby declare that the products VSBV with product ID No. CE-0085AP0151 comply with the requirements of the listed Directives and Standards.

Directives:

- 2014/68/EU – PED
- 2011/65/EU – RoHS II
- 2015/863/EU – RoHS III

Regulation:

- (EU) 2016/426 – GAR

Standards:

- DIN 33821

The relevant product corresponds to the tested type sample.

The production is subject to the surveillance procedure pursuant to Regulation (EU) 2016/426 Annex III and Directive 2014/68/EU Annex III Module D1. This declaration of conformity is issued under the sole responsibility of the manufacturer.

Elster GmbH

2.3 UKCA certified



Gas Appliances (Product Safety and Metrology etc. (Amendment etc.) (EU Exit) Regulations 2019)
DIN 33821

2.4 Eurasian Customs Union



The products VSBV meet the technical specifications of the Eurasian Customs Union.

2.5 REACH Regulation

The device contains substances of very high concern which are listed in the Candidate List of the European REACH Regulation No. 1907/2006. See Reach list HTS at www.docuthek.com.

2.6 China RoHS

Directive on the restriction of the use of hazardous substances (RoHS) in China. Scan of the Disclosure Table China RoHS2, see certificates at www.docuthek.com.

3 Function

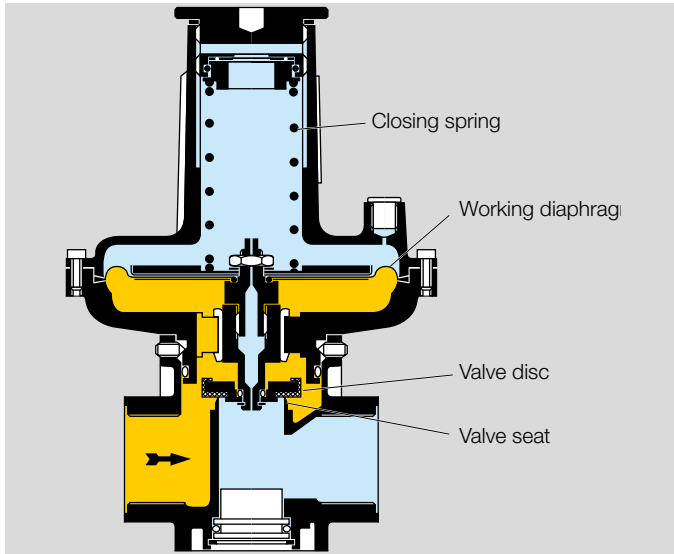

Relief valve VSBV is closed by a spring when no pressure is applied.

The gas flows through the inlet area to the space beneath the working diaphragm. If the inlet pressure reaches the pressure set by the closing spring, the diaphragm raises the valve disc from the valve seat. The relief valve opens and the gas can flow to the outlet.

If the inlet pressure has decreased due to the gas flowing out, the valve closes.

A test nipple has been installed to measure the inlet pressure p_U .

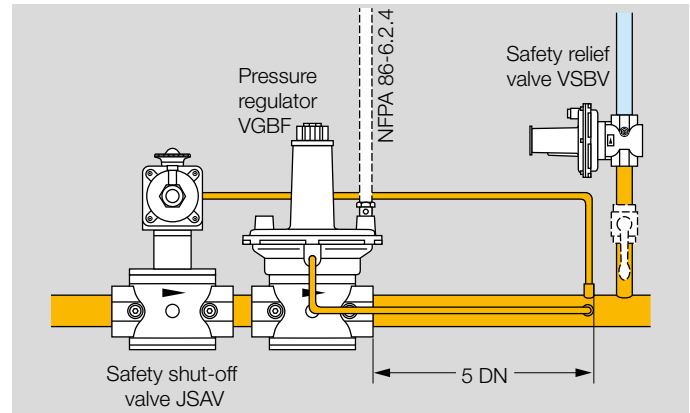

Relief valve VSBV relieves pressure peaks thus preventing the safety shut-off valve JSAV from being activated unintentionally.

4 Selection

Option	VSBV
DN	25
Pipe connection	R, TN
Inlet pressure	40
Pressure measuring point	-0, -4
Opening pressure	Z

Order example

VSBV 25R40-4

4.1 ProFi

A web app selecting the correct product is available at www.adlatus.org.

4.2 Type code

VSBV	Relief valve
25	Nominal size
R	Rp internal thread
TN	NPT internal thread
40	p_U max. 4 bar
-0	No pressure test point
-4	Pressure test point at the inlet
Z	Special adjusting range

5 Project planning information

5.1 Installation

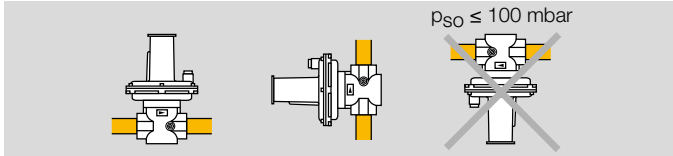

Installation position: for opening pressures up to 100 mbar, spring dome pointing vertically upwards or to the side, not upside down; for other opening pressures, any installation position is possible. If the spring dome is pointing to the side, the set opening pressure is reduced by 4 mbar; if the spring dome is pointing downwards, it is reduced by 8 mbar.

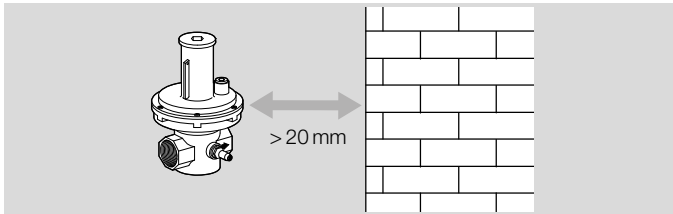

The relief valve VSBV must not be in contact with masonry. Minimum clearance 20 mm.

Do not store or install the unit in the open air.

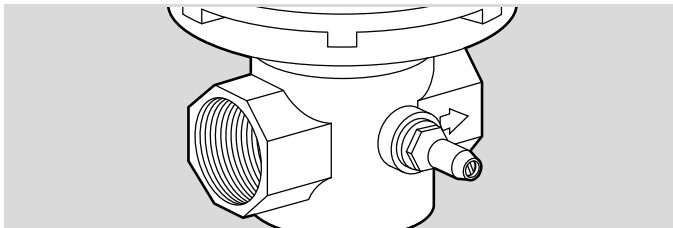

The unit is delivered with a test nipple fitted to the side to measure the inlet pressure p_u .

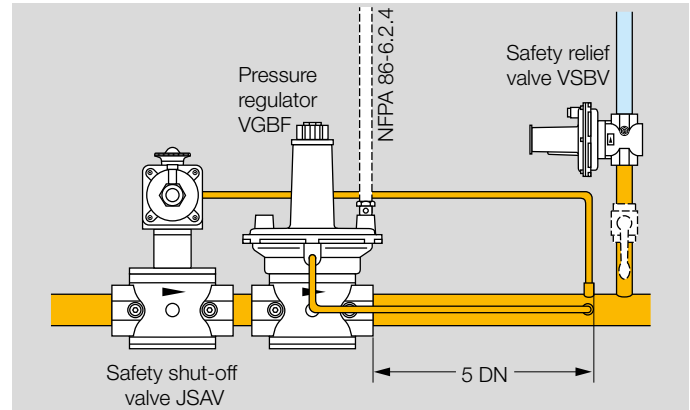

If the controls downstream of a gas pressure regulator are not resistant to the supply pressure, EN 746-2 prescribes a safety shut-off valve upstream and a relief valve downstream of the gas pressure regulator – regardless of how high the inlet pressure is.

5.2 Pressure levels

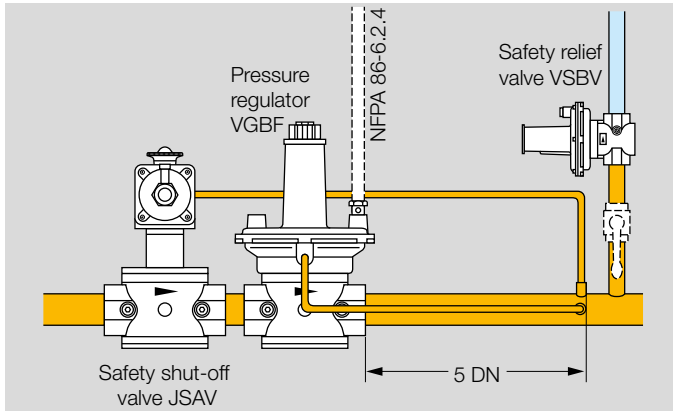

The opening pressure of the safety relief valve (VSBV) and trip pressures for the safety shut-off valve (JSAV) are calculated on the basis of the outlet pressure set on the pressure regulator.

The “Pressure levels for setting GPR, SRV and SSV” app helps to calculate the various setting values, see www.ad-latus.org.

5.3 Hydrogen



Other hydrogen-compatible products can be found here: [Technical Information](#), [Products for hydrogen](#).

6 Accessories

6.1 Exhaust ABG

Potentially explosive areas may be created at the discharge points of relief lines. The exhaust ABG enables the vertical, upwards exhaustion of the gases over the roof edges into the atmosphere. The exhaust ABG may be connected to relief valves or manifold lines. It is suitable for pressures on the exhaust outlet of up to 1.5 bar (21.75 psig). The exhaust's outlet openings are fitted with anti-bird grilles.

It is the responsibility of the operator to determine the explosion-hazard areas and to specify and document these zones. Instructions for this can be found in the DVGW note G442, the rules and regulations issued by employer's liability insurance associations, the German Technical Rules for Industrial Safety and Health (TRBS), as well as further relevant publications.

6.1.1 Installation

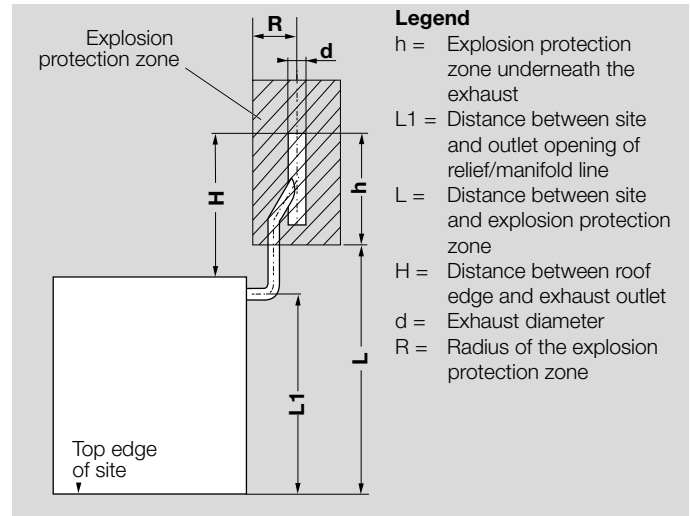

Install the exhaust ABG so as to guarantee the free flow and jet spreading of the outflowing gas. The exhaust should clearly project out over the roof edge ($H = 15 \times d$). The outlet openings of the relief or manifold lines should lie ≥ 1.8 m (6 ft) over the top edge of the site (**L1**). The connection pipe for the exhaust ABG can be shortened, where applicable. Here it should be noted that the explosion protection zone underneath the exhaust remains big enough ($h = 10 \times d$) and the distance between the explosion protection zone and the site is ≥ 2 m (6.6 ft) (**L**).

6.1.2 Selection

Exhaust ABG 25/40, Order No. 03165011,

Exhaust ABG 50/80, Order No. 03165013.

6.1.3 Type code

ABG	Exhaust
25	Connection pipe nominal diameter: DN 25
50	Connection pipe nominal diameter: DN 50
/40	Exhaust nominal diameter: DN 40
/80	Exhaust nominal diameter: DN 80

6.1.4 Technical data

Version: welded, hot-galvanized steel.

Connection pipe length: 1100 mm (43.3 inches).

Dimensions

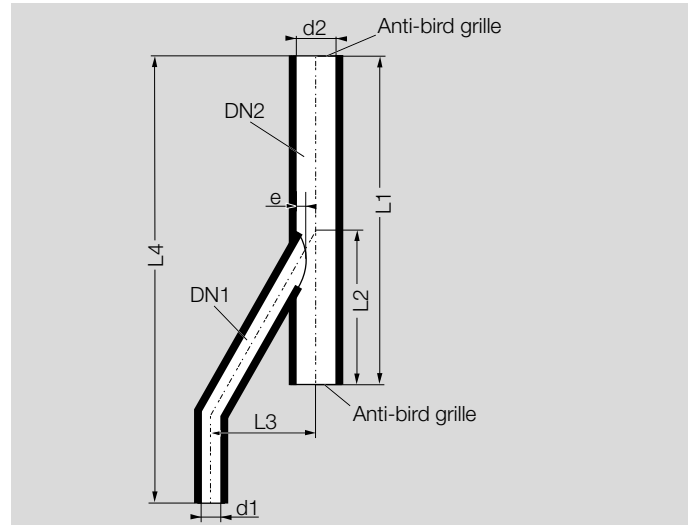

Type	Nominal size DN		Overall dimensions in mm (inches)					Dimensions in mm (inches)			
	DN1	DN2	L1	L2	L3	L4	e	DN1		DN2	
								d1	Wall thickness	d2	Wall thickness
ABG 25/40	25	40	350 (13.8)	160 (6.3)	130 (5.12)	1100 (43.3)	4.0 (0.16)	33.7 (1.33)	2.6 (0.1)	48.3 (1.9)	2.6 (0.1)
ABG 50/80	50	80	560 (22.05)	250 (9.84)	200 (7.87)	1100 (43.3)	8.0 (0.31)	60.3 (2.37)	2.9 (0.11)	88.9 (3.5)	3.2 (0.13)

7 Technical data

7.1 Ambient conditions

Icing, condensation and dew in and on the unit are not permitted.

Avoid direct sunlight or radiation from red-hot surfaces on the unit. Note the maximum medium and ambient temperatures!

Avoid corrosive influences, e.g. salty ambient air or SO₂.

The unit may only be stored/installed in enclosed rooms/buildings.

Medium and ambient temperatures: -15 to +60°C (5 to 140°F).

Long-term use in the upper ambient temperature range accelerates the ageing of the elastomer materials and reduces the service life (please contact manufacturer).

Storage and transport temperatures: -15 to +40°C (5 to 104°F).

This unit is not suitable for cleaning with a high-pressure cleaner and/or cleaning products.

7.2 Mechanical data

Gas types: natural gas, town gas, landfill gas, LPG (gaseous) (Fluid Group 1 pursuant to Directive 2014/68/EU), hydrogen and biogas (max. 0.02 %-by-vol. H₂S). The gas must be dry in all temperature conditions and must not contain condensate.

Inlet pressure p_U : up to 4 bar.

Accuracy group: AG 10.

Valve housing: aluminium,
valve seat and stem: aluminium,
diaphragm: Perbunan,
valve plate: NBR.

Internal thread: Rp 1 to ISO 7-1.

Weight: 1.6 kg.

7.3 Dimensions

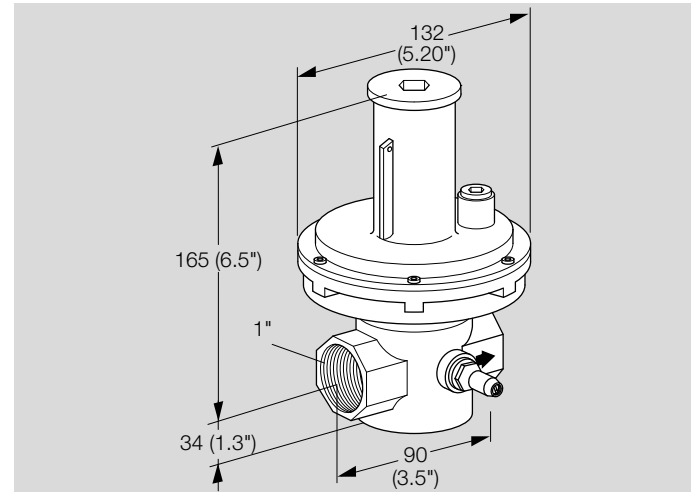

8 Spring table

Opening pressure range [mbar]	Marking	Order No.
20 – 40	red	75441805
35 – 50	yellow	75441806
45 – 75	green	75441807
70 – 170*	blue	75441808
165 – 330	black	75441809
320 – 500	white	75441810

* Standard spring

9 Maintenance cycles

At least once a year, at least twice a year in the case of biologically produced methane.

For more information

The Honeywell Thermal Solutions family of products includes Honeywell Combustion Safety, Eclipse, Exothermics, Hauck, Kromschroder and Maxon. To learn more about our products, visit ThermalSolutions.honeywell.com or contact your Honeywell Sales Engineer.

Elster GmbH
Strotheweg 1, D-49504 Lotte
T +49 541 1214-0
hts.lotte@honeywell.com
www.kromschroeder.com

© 2023 Elster GmbH

We reserve the right to make technical modifications in the interests of progress.

